

THE INFORMATION CONTAINED IN THIS DRAWING IS THE SOLE PROPERTY OF DIXON BAYCO LIMITED. ANY REPRODUCTION IN PART OR WHOLE WITHOUT THE WRITTEN PERMISSION OF DIXON BAYCO LIMITED IS PROHIBITED.

REVISION TABLE				
REV.	ECO	DESCRIPTION	DATE	APPROVED
**	**	**	**	**

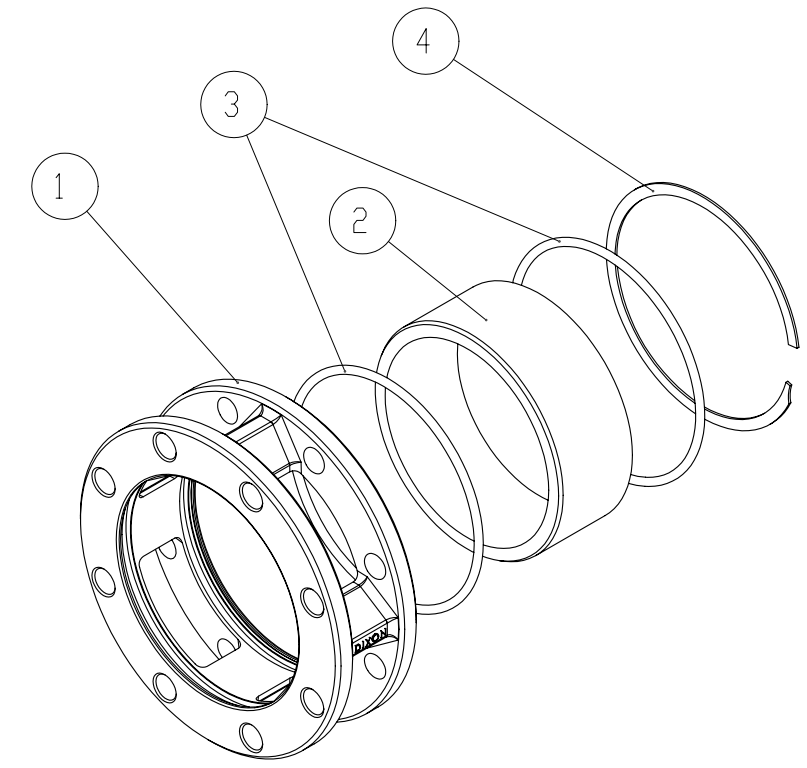
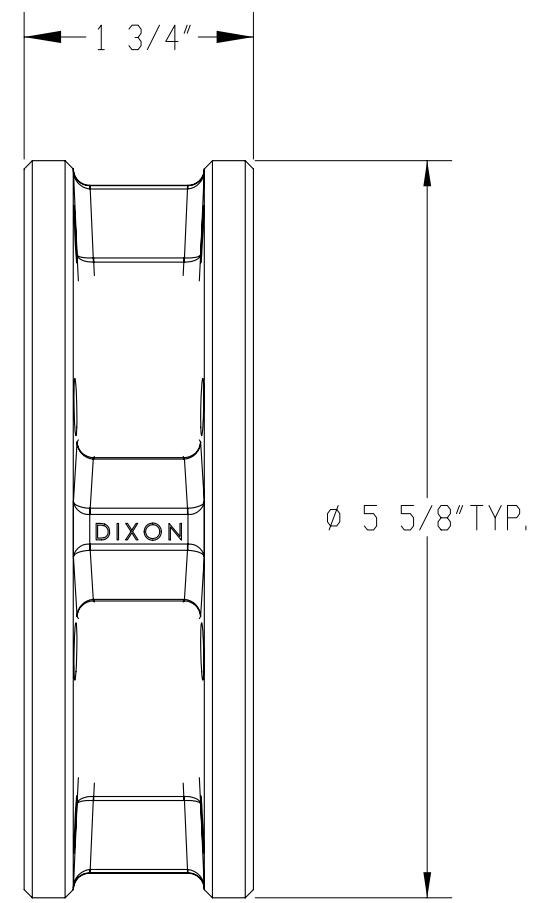
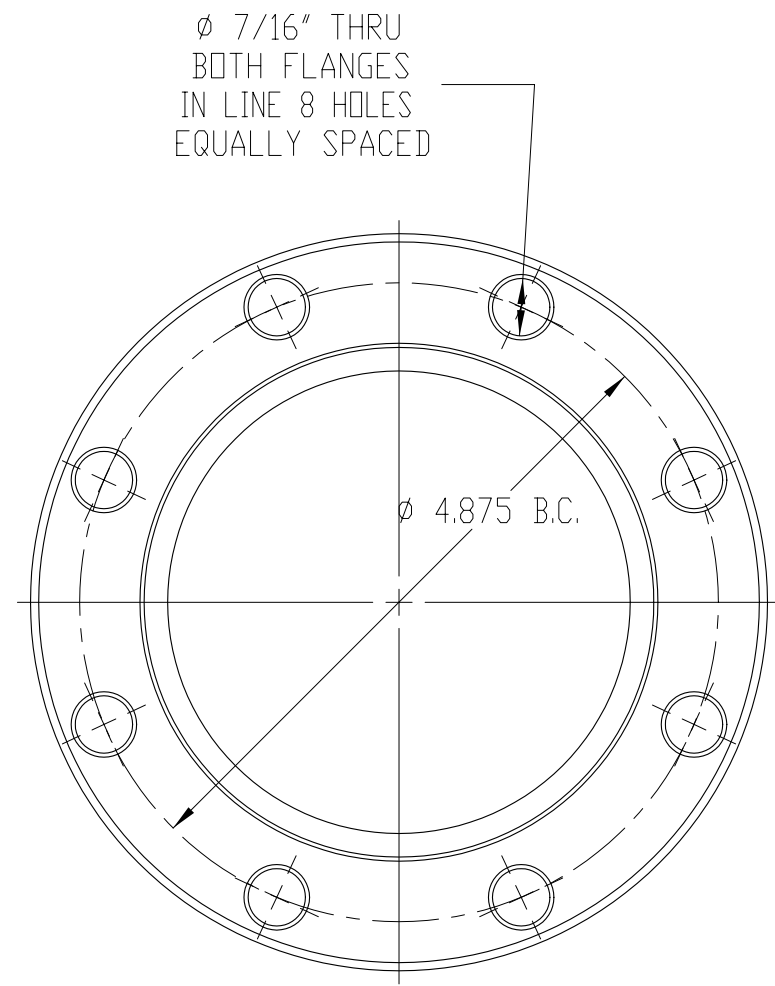

ITEM NO.	DESCRIPTION	QTY.
1	Housing	1
2	Sight Glass	1
3	O-ring	2
4	Retaining Ring	1

DIMENSIONS ARE IN INCHES UNLESS OTHERWISE SPECIFIED TOLERANCES ARE:	DIXON BAYCO		DIXON BAYCO LIMITED 2200 LOGAN AVE. WINNIPEG, MB. R2R 0J2 PHONE (204) 633-5650 FAX (204) 633-6119	
	CAD GENERATED DRAWING; DO NOT MANUALLY UPDATE. DO NOT SCALE DRAWING		TITLE 5200-SFI3	
MATERIAL	APPROVALS	DATE	SIZE DWG. NO.	REV.
	DRAWN BY F.FIDELIND	APR. 18/07	B	0
	CHECKED C.MARTENS	APR. 18/07	CUSTOMER DRAWING	
			ECO	SHEET 1 OF 1